

Polydos Preparation & Dosing Systems

General

Grundfos Polydos preparation systems are fully automatic systems for preparation of solutions from dry or concentrated liquid polymers. The concentration of the final solution is achieved by proportionally mixing the polymer with intake water. The concentration is set at the touch screen of the control cabinet. The maturing time of the polymer solution depends on the discharge rate and the hydraulic capacity of the system.

Polydos 420E for liquid polymer

- PPH tank with 2 chambers: mixing and maturing
- Mixing chamber fitted with electric stirrer
- Polymer dosing line with ball valve, controlled outlet, drain connections and tank overflow, all mounted directly to the tank
- Control cabinet with PLC and multilingual graphic display
- Communication options: Profibus, Modbus, Ethernet
- Feeding pump for concentrated liquid polymer
- Ultrasonic sensor for continuous level control



Technical Data

	Material	Capacity
Polydos 420E	Stirrer shaft and impeller: SS Pipings and connections: uPVC	50 to 2000 l/h*



GRUNDFOS 

Product Description

Component Specifications:

Polymer Dosing and Mixing Unit

The polymer skid system is designed to mix liquid polymer in proportion to flow. The system utilizes a CRIE pump controlled by a VFI flow meter, a DDA dosing pump and a static mixer. The components are designed for durability, accuracy, and ease of operation.

The polymer skid system consists of the following primary components:

CRIE Pump: A centrifugal pump used to transport the liquid polymer.

VFI Flow Meter: Measures the flow rate of the liquid polymer.

DDA Dosing Pump: Precisely doses the required amount of polymer emulsion into the line.

Static Mixer: Mixes the polymer emulsion with the main flow.

Pipework: PVC-U DN32 PN16 flange connection, compatible with DIN/ANSI/JIS standards.

Frame and Mounting Brackets: Constructed of 304 stainless steel for durability and corrosion resistance.

System Operation:

Flow Measurement: The VFI flow meter measures the flow rate of the liquid polymer.

CRIE Pump Control: The VFI flow meter sends a signal to the CRIE pump to adjust its flow rate to match the measured flow.

Dosing Pump Activation: The CRIE pump sends a signal to the DDA dosing pump to dispense the appropriate amount of polymer emulsion.

Mixing: The polymer emulsion is injected into the line and mixed with the main flow using a static mixer.

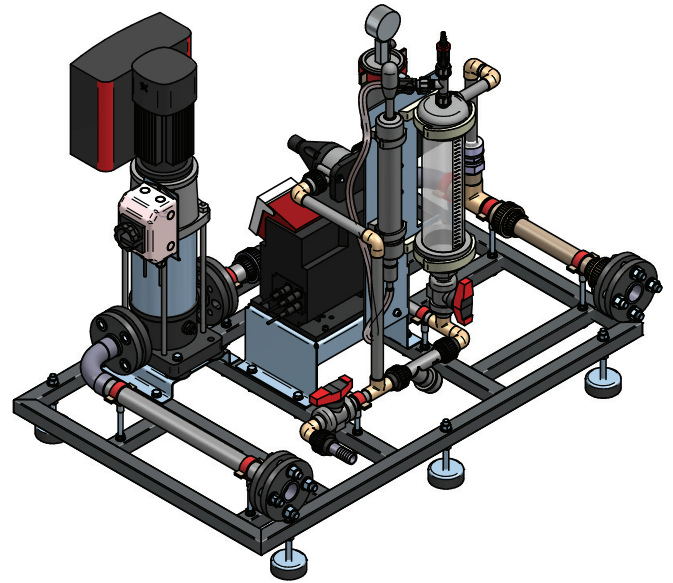
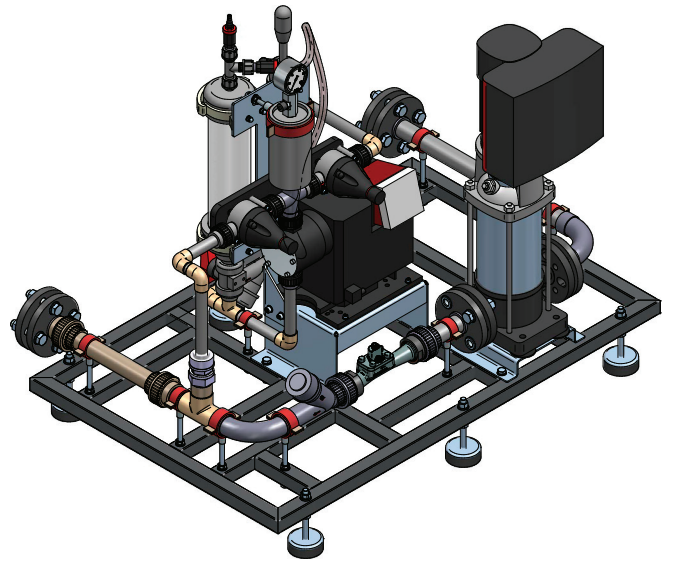

GRUNDFOS 